

Mandrel collet for small bores

Item description/product images

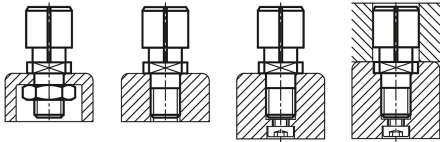

Description

Material:

Stainless steel 1.4305.

Version:

Bright.

Note:

The mandrel collet is used in small bores (Form A for through holes, Form B for through or blind holes) to position and clamp workpieces. Operated manually from above using a hexagon key. The mandrel OD can be ground to the desired size. The locating hole in the workpiece should have an H7 tolerance.

D min. = smallest permissible diameter to which "D" may be ground.

- applicable for holes from $\varnothing 5$ to $\varnothing 12.5$ mm
- compact design, small installation space
- simple handling
- mounting in any position
- different installation types possible
- large area pressure protects the workpiece surface
- individually adaptable to the diameter

Form A: for through holes.

Form B: for through or blind holes.

Assembly:

If required, diameter D can be adapted to suit the diameter being held. To do this, expand the mandrel collet ca. 0.2 mm over the required diameter. Grind the OD of the mandrel collet to suit the ID of the workpiece bore.

Drawings

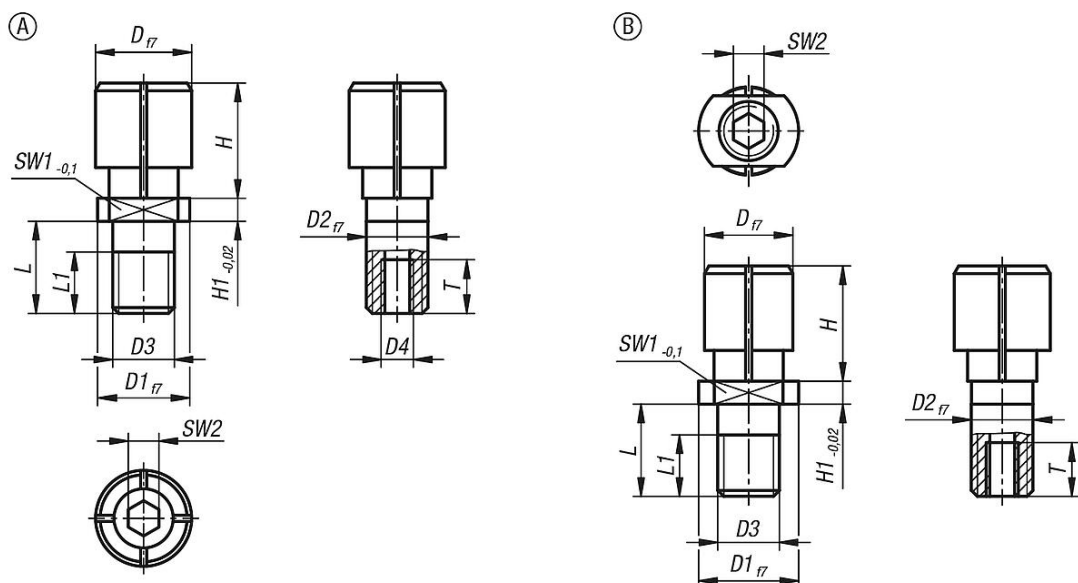

Mandrel collet for small bores

Overview of items

Mandrel collet for small bores

Order No.	Form	D	D min.	D1	D2	D3	D4	H	H1	L	L1	SW1	SW2	T	Tightening torque max. Nm	Clamping force max. kN
K1293.105060	A	6	5	10	6	M6	M3	8	2,5	10	6	6	2	6	0,9	0,19
K1293.106080	A	8	6	10	6	M6	M3	10	2,5	10	6	6	2,5	6	2,4	0,34
K1293.108100	A	10	8	12	8	M8	M4	12	3	12	8	8	3	7	4,4	0,62
K1293.110125	A	12,5	10	12	8	M8	M4	15	3	12	8	8	4	7	8,1	0,62
K1293.204050	B	5	4	10	8	M8	-	6,5	2,5	9,8	6	8	2	2	0,9	0,15
K1293.205060	B	6	5	12	8	M8	-	8	2,5	9,8	6	10	2	2	0,9	0,19
K1293.206080	B	8	6	12	8	M8	-	10	2,5	9,8	6	10	2,5	2,5	2,4	0,34
K1293.208100	B	10	8	12	8	M8	-	12	3	11,8	8	10	3	3	4,4	0,62
K1293.210120	B	12	10	14	10	M10	-	15	3	11,8	8	10	4	4	8,1	0,8