

Positioning the base elements



Double side tombstone K0803, cube tombstone K0805 and subplates K0806 have two positioning options:

a) Positioning on subplates for machine-tools acc. to DIN 55 201.

Positioning procedure:

1. Insert locating pin in the centre bore of the subplate.
2. Position the tombstones, cube tombstones and subplates over the central hole.
3. Use the locating pin for the aligning hole to align the basic elements.

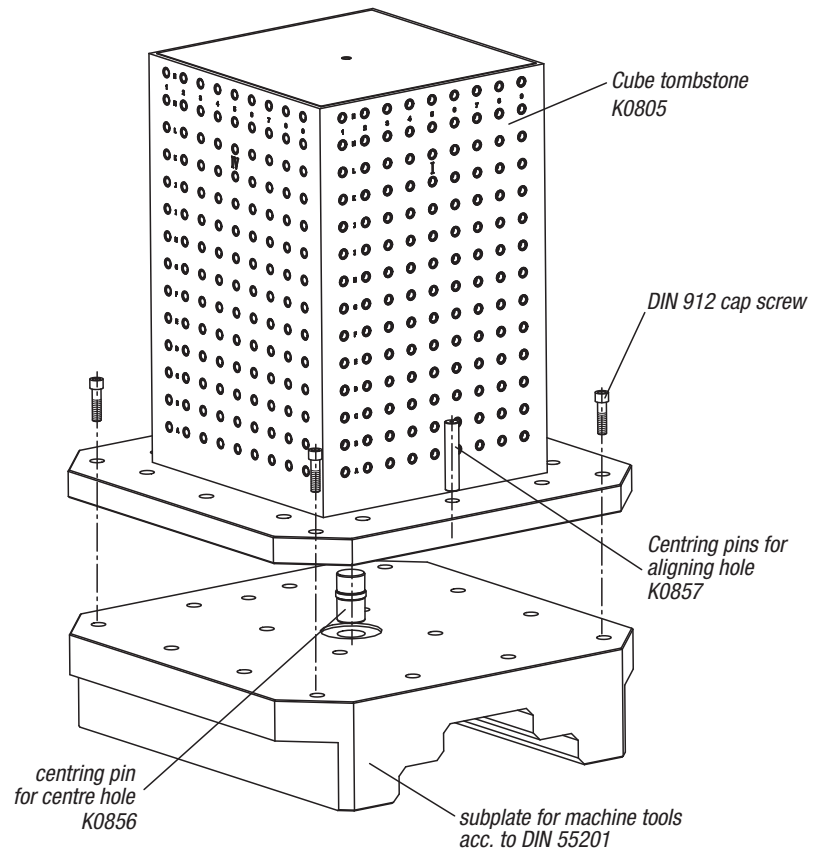

b) Positioning on subplates for machine tools acc. to JIS 6337-1980.

Positioning procedure:

1. Mount stop plates on the machine table.
2. Attach stop points to the reference faces (stop plates) using socket head screws.

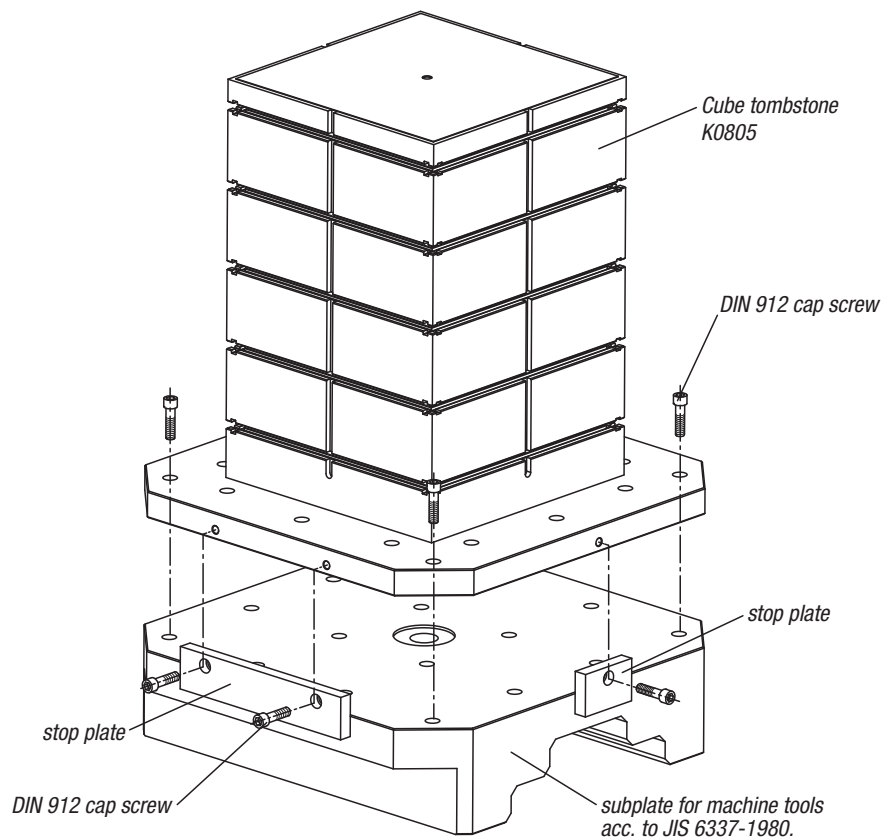

on machine tables



Locating pins are used for positioning tooling plates K0800. The tooling plates each have four precision holes for the locating pins (two holes on each axis). An M6 screw inserted into the head of the locating pin is used to insert this pin accurately into the T-slots or to remove it.

